

WIPO IP Facts and Figures 2018

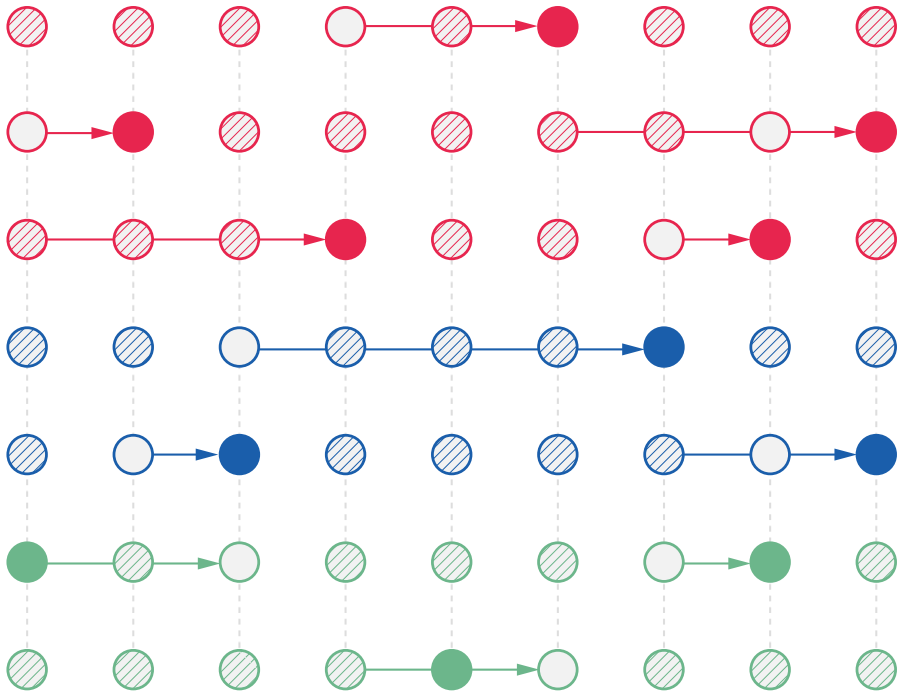



WIPO IP Facts and Figures 2018



Except where otherwise indicated, this work is licensed under the Creative Commons Attribution 3.0 IGO License.

The user is allowed to reproduce, distribute, adapt, translate and publicly perform this publication, including for commercial purposes, without explicit permission, provided that the content is accompanied by an acknowledgement that WIPO is the source and that it is clearly indicated if changes were made to the original content.

Adaptation/translation/derivatives should not carry any official emblem or logo, unless they have been approved and validated by WIPO. Please contact us via the WIPO website to obtain permission.

For any derivative work, please include the following disclaimer: "The Secretariat of WIPO assumes no liability or responsibility with regard to the transformation or translation of the original content."

When content published by WIPO, such as images, graphics, trademarks or logos, is attributed to a third-party, the user of such content is solely responsible for clearing the rights with the right holder(s).

To view a copy of this license, please visit:
<https://creativecommons.org/licenses/by/3.0/igo/>

The designations employed and the presentation of material throughout this publication do not imply the expression of any opinion whatsoever on the part of WIPO concerning the legal status of any country, territory or area or of its authorities, or concerning the delimitation of its frontiers or boundaries.

This publication is not intended to reflect the views of the Member States or the WIPO Secretariat.

The mention of specific companies or products of manufacturers does not imply that they are endorsed or recommended by WIPO in preference to others of a similar nature that are not mentioned.

© WIPO, 2018

World Intellectual Property
Organization
34, chemin des Colombettes
P.O. Box 18
CH-1211 Geneva 20
Switzerland

ISBN: 978-92-805-3004-9



Attribution 3.0 IGO license
(CC BY 3.0 IGO)

Printed in Switzerland

Table of contents

Introduction	5
--------------	---

Global intellectual property applications and active IP rights

1. Total applications worldwide	7
2. Percentage shares of IP filing activity by region	8
3. IP rights in force	9

Patents and utility models

4. Percentage shares of total patent applications by the top five offices	11
5. Patent applications for the top 10 offices	12
6. Patent applications for offices of selected middle-income countries	13
7. Resident patent applications relative to GDP for the top 10 origins	14
8. The top three technology fields for each of the top five origins, 2014–2016	15
9. PCT international applications for the top 10 origins	16
10. Top 10 PCT applicants	17
11. Utility model applications for the top 10 offices	18
12. Utility model applications for offices of selected middle-income countries	19

Trademarks

13. Percentage shares of total trademark filing activity by the top five offices	21
14. Application class counts for the top 10 offices	22
15. Application class counts for offices of selected middle-income countries	23

16.	Resident trademark application class count relative to GDP for selected origins	24
17.	The top three industry sectors for each of the top five origins	25
18.	Madrid international applications for the top 10 origins	26
19.	Top 10 Madrid applicants	27

Industrial designs

20.	Percentage shares of total design filing activity by the top five offices	29
21.	Application design counts for the top 10 offices	30
22.	Application design counts for offices of selected middle-income countries	31
23.	Resident application design count relative to GDP for the top 10 origins	32
24.	The top three industry sectors for each of the selected origins	33
25.	Designs in Hague international applications for the top 10 origins	34
26.	Top 10 Hague applicants	36

Additional information

Statistical tables	39
Statistical resources	47
Glossary	48

Introduction

IP Facts and Figures 2018 from the World Intellectual Property Organization (WIPO) provides an overview of intellectual property (IP) activity using the latest available year of complete statistics. The figures presented here are drawn from WIPO's more comprehensive *World Intellectual Property Indicators 2018*.

IP Facts and Figures serves as a quick reference guide covering four types of industrial property: patents, utility models, trademarks and industrial designs. It focuses primarily on application data, which is the most often used measure of IP activity. Trademark application data refer to class counts – the number of classes specified in applications; this affords a better comparison of international trademark filing activity across IP offices, as applications in some jurisdictions may specify multiple classes of goods and services while others require a separate application for each class. Similarly, industrial design data refer to design counts – the number of designs contained in applications.

Unless otherwise stated, all data refer to activity in calendar year 2017 and growth means annual growth, that is, the change from 2016 to 2017.

Please note that, due to the continual updating of statistics, data provided in this publication may differ from previously published figures and from data available on WIPO's web pages. For more in-depth analysis of WIPO and/or national office IP statistics, please visit the following Internet pages:

IP statistics: www.wipo.int/ipstats

World Intellectual Property Indicators: www.wipo.int/ipstats/en/wipi

Contact information:

Economics and Statistics Division

e-mail: ipstats.mail@wipo.int

Global intellectual property applications and active IP rights

Worldwide filings for patents, trademarks and industrial designs reached record heights in 2017

1. Total applications worldwide

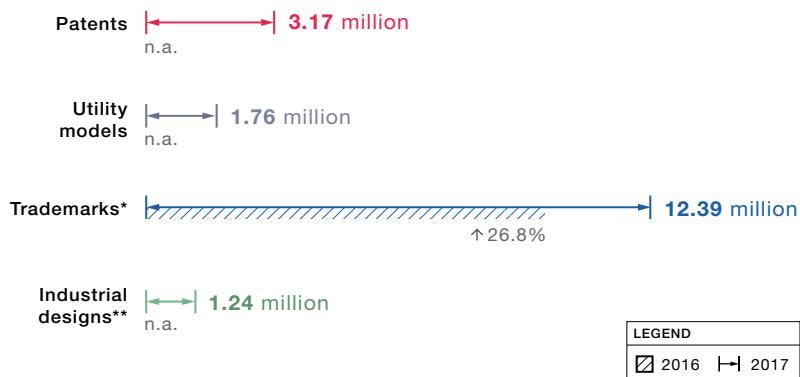

* refers to class count – the total number of goods and services classes specified in trademark applications.

** refers to design count – the total number of designs contained in industrial design applications.

n.a. indicates not available. China's 2017 data are not comparable with its previous year's data for patent, utility model and industrial design applications due to a change in how this office counts the applications it receives. As China accounts for large shares of global filings for these IP rights, it is not possible to report accurate 2017 worldwide growth rates.

Source: WIPO Statistics Database, September 2018.

Innovators around the world filed 3.17 million patent applications in 2017, representing an eighth consecutive year of growth. Trademark filing activity amounted to 12.39 million, up 26.8% and representing the third consecutive year of double-digit growth. Worldwide industrial design filing activity exceeded 1.24 million, while applications for utility models totaled 1.76 million.

Asia has strengthened its position as the region with the most IP filing activity

2. Percentage shares of IP filing activity by region

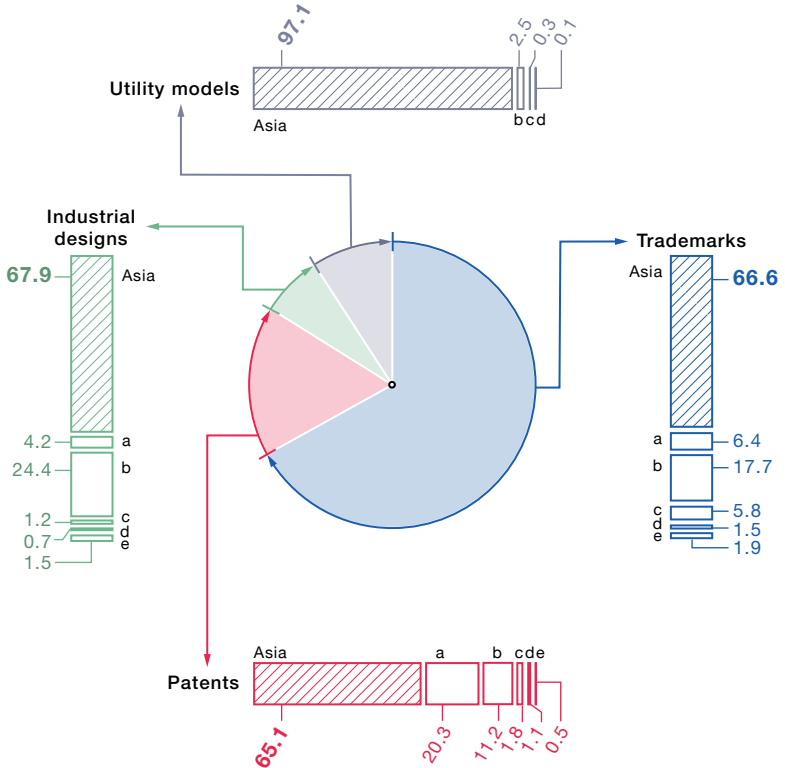

LEGEND	
▨	Asia
a	North America
b	Europe
c	Latin America and the Caribbean
d	Oceania
e	Africa

Source: WIPO Statistics Database, September 2018.

Combined, IP offices in Asia received the highest numbers of applications for patents, utility models, trademarks and industrial designs, including 65.1% of all patent applications worldwide. Asia has seen an increase in its share of all applications filed worldwide for these four IP rights over the last decade.

Note that North American offices do not offer utility model registration and are therefore not included in the chart for that IP right.

There were around 43.2 million active trademark registrations and almost 14 million patents in force in 2017

3. IP rights in force

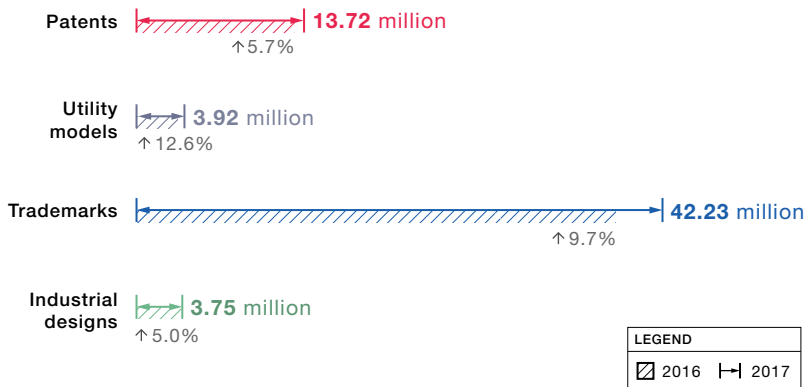

Source: WIPO Statistics Database, September 2018.

There were 13.72 million patents in force worldwide in 2017, of which around 2.98 million were in force in the United States of America (U.S.), 2.1 million in China and 2 million in Japan. Of the 43.23 million active trademark registrations worldwide, 14.9 million were in China alone, followed by 2.2 million in the U.S. and 1.9 million in Japan. The total number of industrial designs in force worldwide grew by 5% to reach 3.75 million. While China accounted for 39% of the world total of industrial designs in force – under half – it accounted for nearly all of the utility models in force (92%).

Patents and utility models

The top five offices accounted for around 85% of the world total

4. Percentage shares of total patent applications by the top five offices

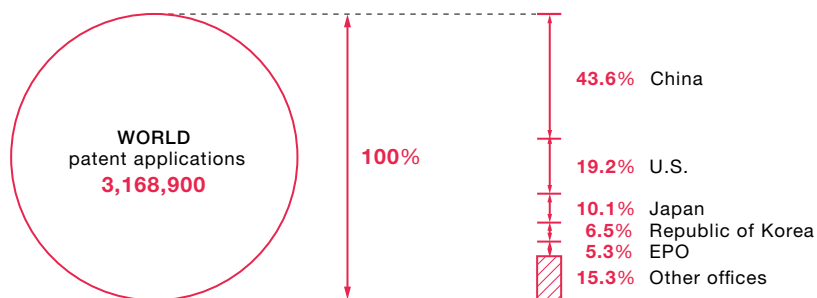

EPO is the European Patent Office.

Source: WIPO Statistics Database, September 2018.

Not only did the top five IP offices receive around 85% of the 3.17 million patent applications filed worldwide in 2017, a considerable share (43.6%) was filed in China alone, primarily by Chinese residents. The next largest shares went to the offices of the U.S., Japan, the Republic of Korea and the European Patent Office (EPO).

China received 1.38 million patent applications, more than double the number received by the U.S.

5. Patent applications for the top 10 offices

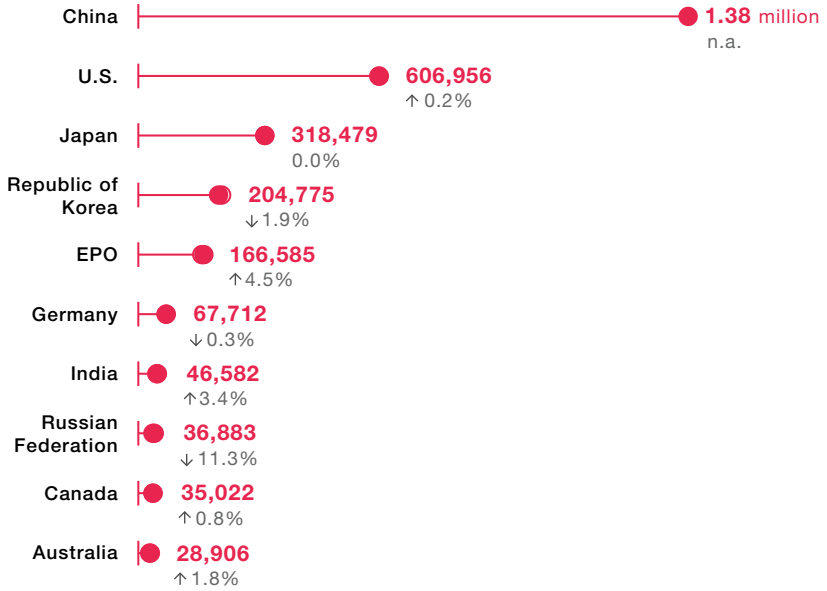

LEGEND	
○	2016
●	2017

n.a. indicates not available. China's 2017 data are not comparable with its previous year's data due to a change in how this office counts the applications it receives. For this reason, it is not possible to report China's 2017 growth rate.

EPO is the European Patent Office.

Source: WIPO Statistics Database, September 2018.

China's office received a record total of 1.38 million patent applications in 2017, more than double the number of applications received by that of the U.S. (606,956). The office of Japan ranked third with 318,479 applications, followed by the office of the Republic of Korea (204,775) and the EPO (166,585). Among the top 10 offices, those of India (+3.4%) and the EPO (+4.5%) saw a strong growth in filings in 2017.

ARIPO and OAPI saw applications return to growth in 2017 following a decline in each of the two previous years

6. Patent applications for offices of selected middle-income countries

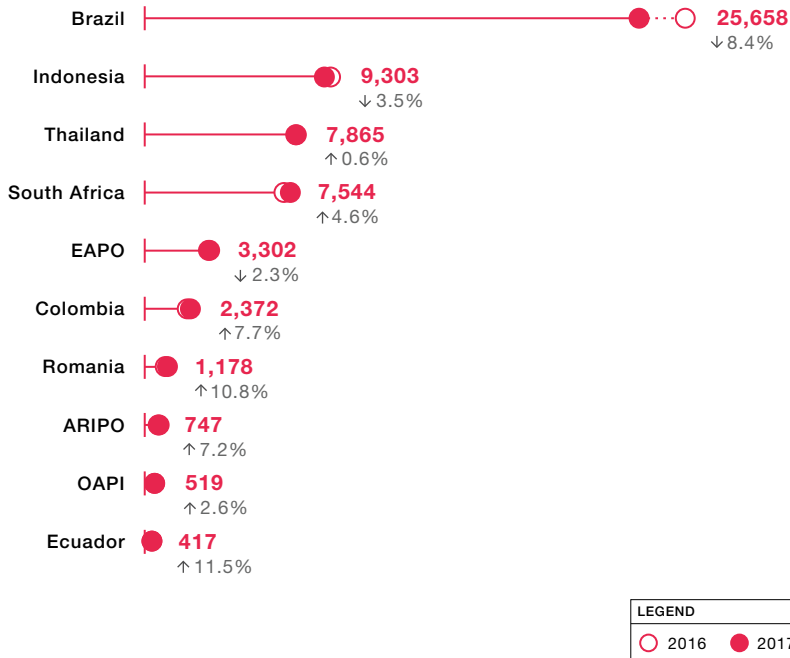

ARIPO is the African Regional Intellectual Property Organization; EAPO is the Eurasian Patent Organization; OAPI is the African Intellectual Property Organization. These regional offices act on behalf of their middle-income member states.

Source: WIPO Statistics Database, September 2018.

Applications filed at the African Regional Intellectual Property Organization (ARIPO) grew by 7.2% in 2017, while the African Intellectual Property Organization (OAPI) received 2.6% more applications in 2017 than in 2016. Among the offices of selected middle-income countries, Ecuador (+11.5%), Romania (+10.8%) and Colombia (+7.7%) recorded particularly high growth in 2017. For numbers of patent applications received by all other IP offices (where available), see the statistical table starting on page 39.

Innovators in the Republic of Korea, China and Japan filed the highest numbers of patent applications per unit of GDP (USD 100 billion)

7. Resident patent applications relative to GDP for the top 10 origins

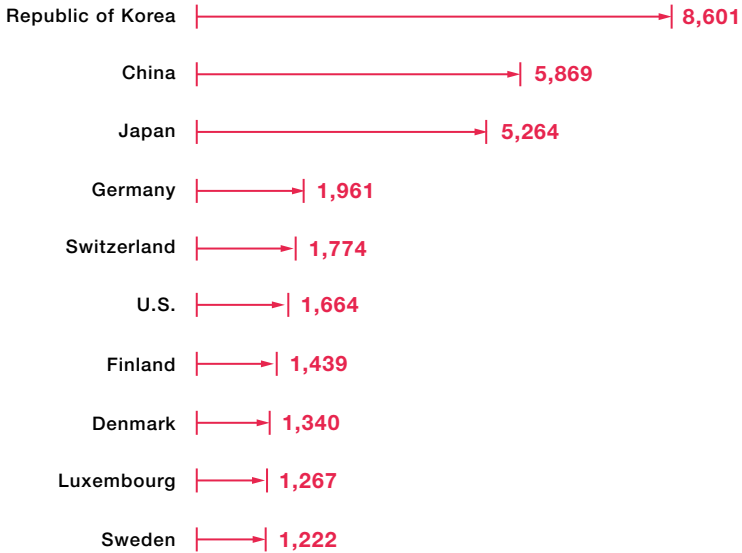

Sources: WIPO Statistics Database and World Bank, September 2018.

Differences in patent activity reflect both the size of each economy and its level of development. However, by weighing the number of applications per country relative to its GDP, it is possible to compare filing activity among countries with economies of very different sizes for an alternative measure.

While China leads the world in the total number of patent applications filed by its residents, on this alternative measure the Republic of Korea outperforms all other countries – its ratio of filing to unit of GDP is considerably higher than those of the two next highest ranked, China and Japan.

Which countries specialize in which technologies?

8. The top three technology fields for each of the top five origins, 2014–2016

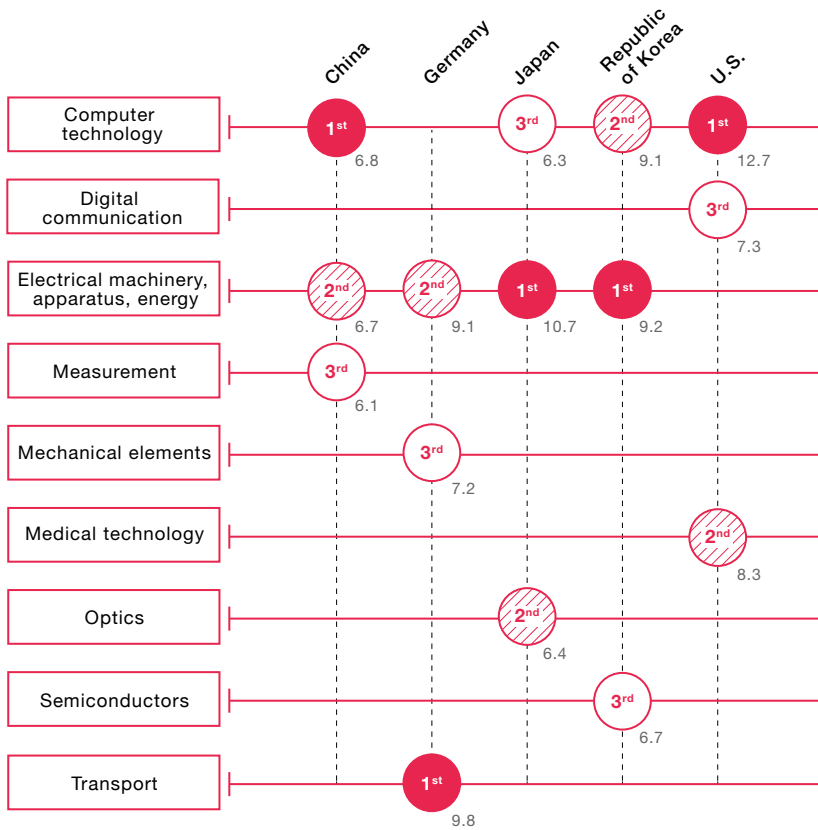

Numbers in gray show percentage share.

Sources: WIPO Statistics Database and EPO PATSTAT database, September 2018.

Analyzing patents by technology shows each country’s areas of strength or specialization. For example, applicants from China and the Republic of Korea filed most intensively in the fields of electrical machinery and computer technology, Germany in transport, Japan in electrical machinery, and the U.S. in computer technology.

China became the second largest user of the PCT System in 2017

9. PCT international applications for the top 10 origins

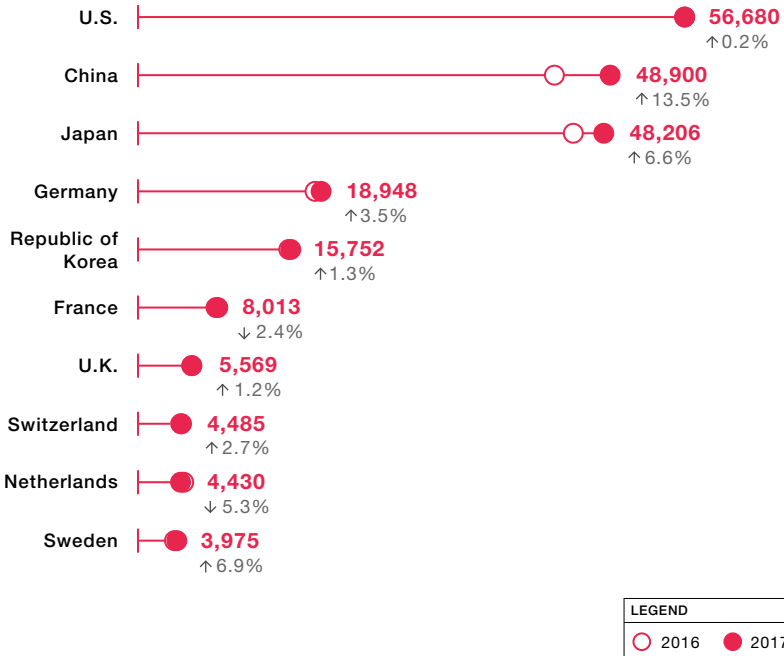

Source: WIPO Statistics Database, September 2018.

The Patent Cooperation Treaty (PCT) System simplifies the process of multiple national patent filings by reducing the requirement to file a separate application in each jurisdiction where protection is sought.

Around 243,500 PCT applications were filed in 2017, up 4.5% on 2016, representing an eighth consecutive year of growth. China, with 48,900 PCT applications, became the second largest source of PCT applications, closing in on long-term leader – the U.S. (56,680). Close behind was Japan (48,206), ranked third.

Huawei Technologies and ZTE Corporation occupied the top two spots for PCT applications

10. Top 10 PCT applicants

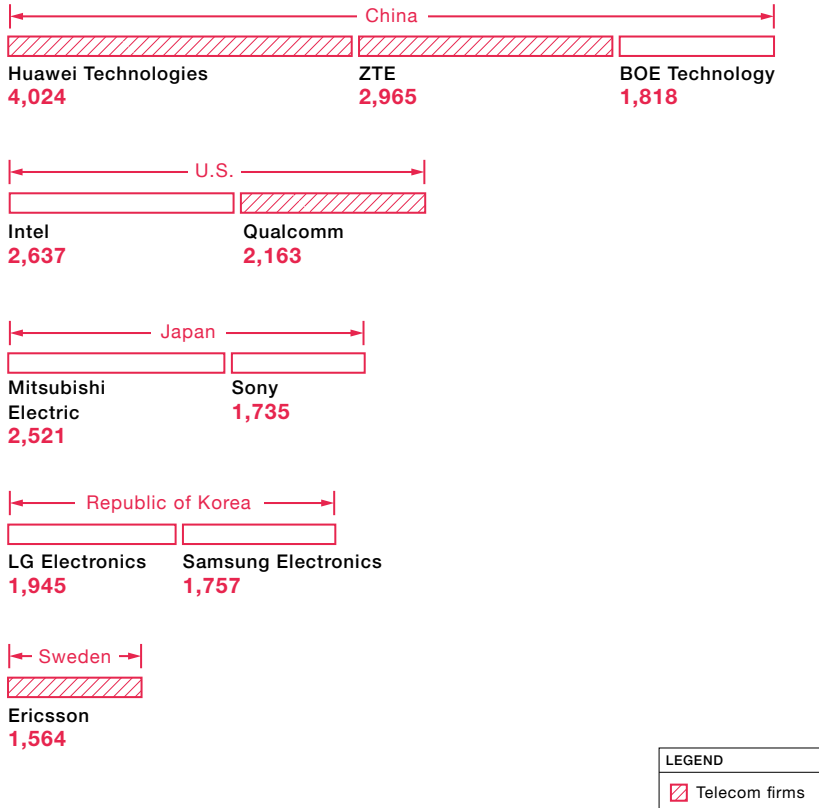

Source: WIPO Statistics Database, September 2018.

Two Shenzhen, China-based telecoms companies – Huawei Technologies (4,024 published PCT applications) and ZTE Corporation (2,965) – occupied the top two spots for PCT applications. They were followed by Intel Corporation of the U.S. (2,637), Mitsubishi Electric Corporation of Japan (2,521) and Qualcomm Incorporated of the U.S. (2,163). Among the top 10 applicants, six filed mainly in digital communications.

The IP office of China received 1.69 million utility model applications

11. Utility model applications for the top 10 offices

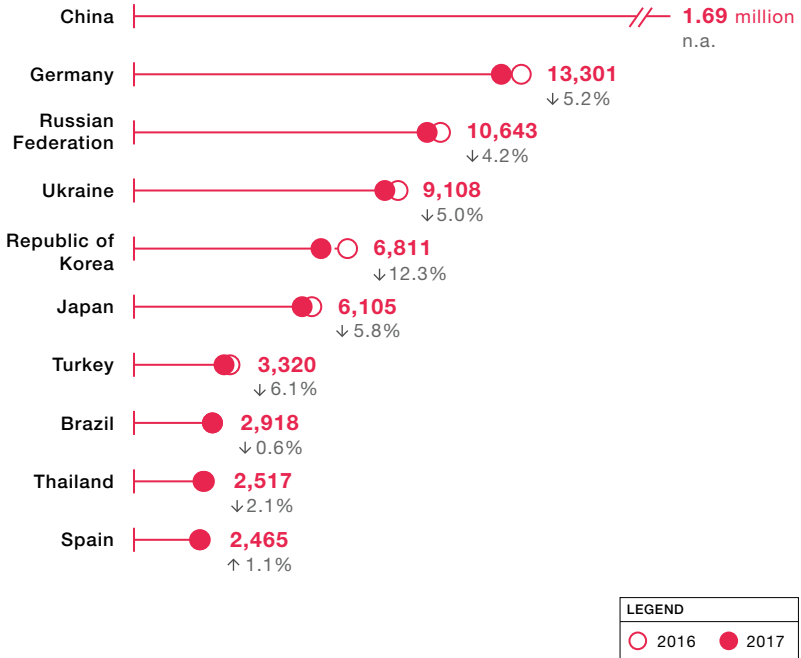

n.a. indicates not available. China's 2017 data are not comparable with its previous year's data due to a change in how this office counts the applications it receives. For this reason it is not possible to report China's 2017 growth rate.

Source: WIPO Statistics Database, September 2018.

A utility model is a special form of patent right which has less stringent requirements than a patent, but gives a shorter term of protection. Utility models are not available in all jurisdictions.

Of the 1.76 million applications filed globally in 2017, the IP office of China received around 1.69 million – 95.8% of the world total – followed by the IP offices of Germany (13,301), the Russian Federation (10,643) and Ukraine (9,108).

Utility model filings grew markedly in the middle-income countries of Kazakhstan and the Philippines

12. Utility model applications for offices of selected middle-income countries

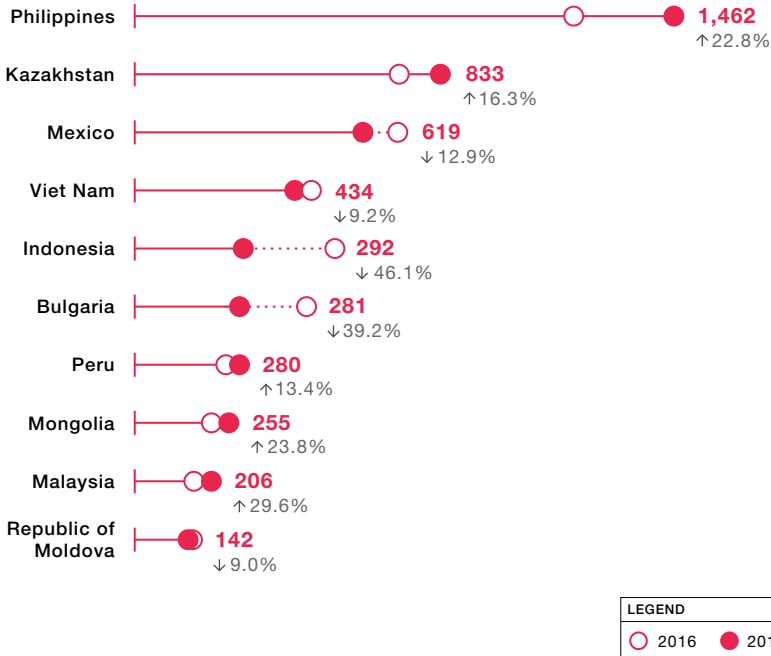

Source: WIPO Statistics Database, September 2018.

The chart above shows the number of utility model applications received by IP offices of selected middle-income countries in 2017. Applications filed in Kazakhstan and the Philippines grew strongly for the second year running. For the number of utility model applications received by all other IP offices (where available), see the statistical table starting on page 39.

Trademarks

Just five offices saw over 60% of all trademark filing activity worldwide

13. Percentage shares of total trademark filing activity by the top five offices

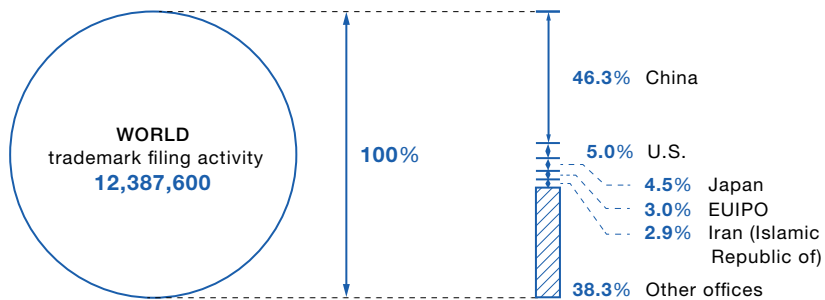

EUIPO is the European Union Intellectual Property Office.

Source: WIPO Statistics Database, September 2018.

In 2017, almost 62% of all trademark filing activity – as measured in class counts – occurred at the top five offices. Increasing its share of the worldwide total, the office of China (46.3%) now accounts for close to half of all global trademark filing activity, primarily from Chinese residents. The other four offices among the top five each accounted for between about 3% and 5% of the total.

China's office continues to record the highest trademark filing activity

14. Application class counts for the top 10 offices

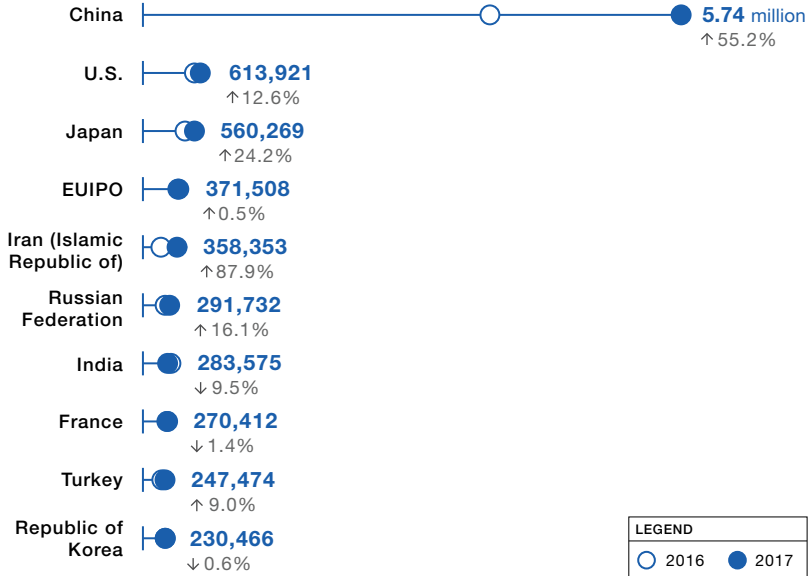

EUIPO is the European Union Intellectual Property Office.

Source: WIPO Statistics Database, September 2018.

The office of China's class count of 5.74 million ranked first followed by a count of 613,921 at the office of the U.S. These have been the top two offices since the early 2000s but, since 2007, China's class count has grown from close to double that of the U.S. to over nine times as much. These two offices were followed by that of Japan (560,269), the European Union Intellectual Property Office (EUIPO; 371,508) and that of the Islamic Republic of Iran (358,353).

Among the top 10 offices, the Islamic Republic of Iran (+87.9), China (+55.2%) and Japan (+24.2) recorded extremely high growth compared to 2016. In contrast, the offices of France, India and the Republic of Korea saw declines in filing activity.

Among middle-income countries, Brazil and Mexico recorded high trademark filing activity

15. Application class counts for offices of selected middle-income countries

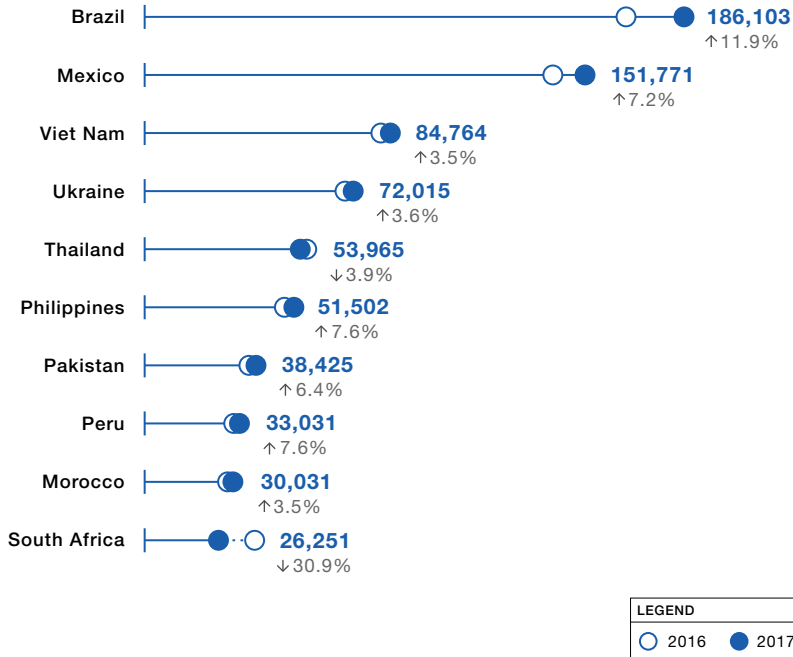

Source: WIPO Statistics Database, September 2018.

Brazil (186,103) and Mexico (151,771) had higher trademark filing activity – as measured in class counts – than many other large middle-income countries.

The chart above shows the total number of classes specified in trademark applications received by the IP offices of a selection of middle-income countries in 2017. For trademark application class counts for all other IP offices (where available), see the statistical table starting on page 39.

China, New Zealand, the Republic of Korea and Turkey all perform strongly on application class count per unit of GDP (USD 100 billion)

16. Resident trademark application class count relative to GDP for selected origins

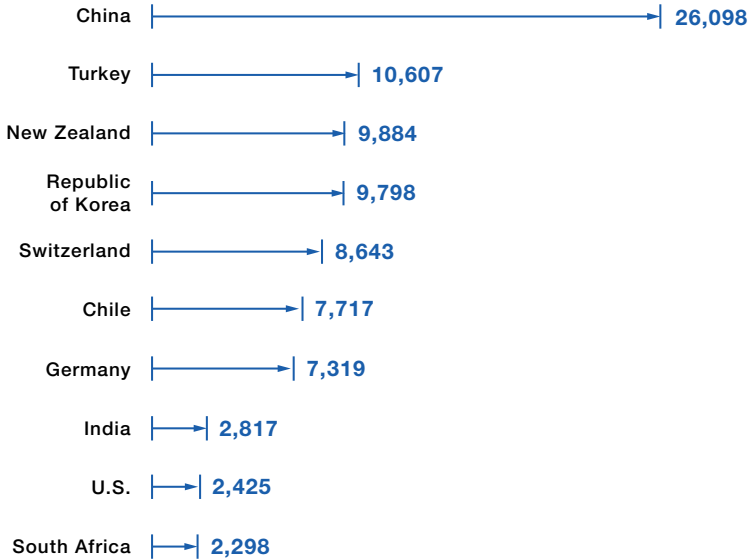

Sources: WIPO Statistics Database and World Bank, September 2018.

Calculating application class count per unit of GDP allows us to compare trademark filing activity in countries with different filing systems (single-class versus multi-class) and economies of very different sizes. On this measure, smaller countries such as Chile and Switzerland rank higher than some large countries with higher class counts in absolute terms, for example the U.S.

What were the top industries for trademark filing by applicants from different countries?

17. The top three industry sectors for each of the top five origins

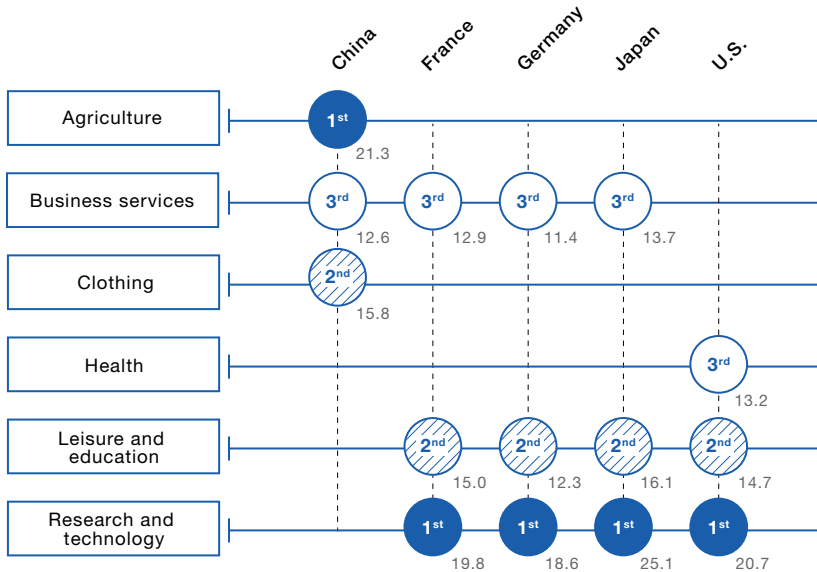

Numbers in gray show percentage share.

Source: WIPO Statistics Database, September 2018.

Using the Nice Classification, trademark applications can be attributed to 10 industry sectors. The chart above shows the top three industry sectors for each of the five origins with the highest trademark filing activity in 2017. Either of research and technology, business services or leisure and education feature among the three sectors attracting the highest volumes of trademark applications from four of these five origins. Agriculture and clothing were among the top three sectors for applicants from China, and health was a top sector for applicants based in the U.S.

The U.S. and Germany are the biggest users of the Madrid System

18. Madrid international applications for the top 10 origins

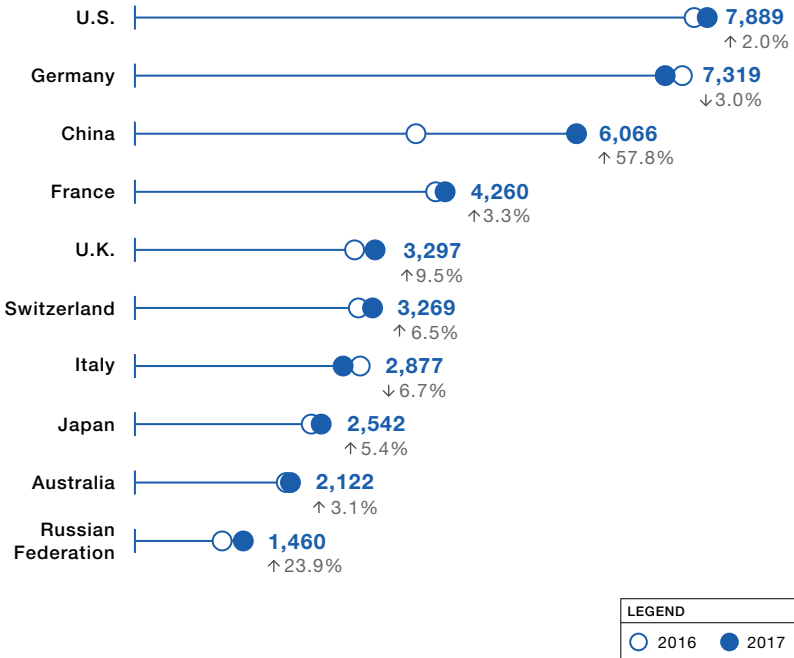

Source: WIPO Statistics Database, September 2018.

The Madrid System makes it possible for a trademark holder to apply for trademark registration in multiple countries by filing a single international application via a national or regional IP office.

Around 57,400 Madrid international applications were filed in 2017, once again setting a record for the number of applications filed. 2017 also marked an eighth consecutive year of growth. This 7.2% increase was driven by strong growth in applications from China (+57.8%), the Russian Federation (+23.9%) and the United Kingdom (U.K.; +9.5%). The highest numbers of international applications were filed by applicants domiciled in the U.S. (7,889) and Germany (7,319).

For the second year in a row, L'Oréal of France heads the list of top Madrid applicants in 2017

19. Top 10 Madrid applicants

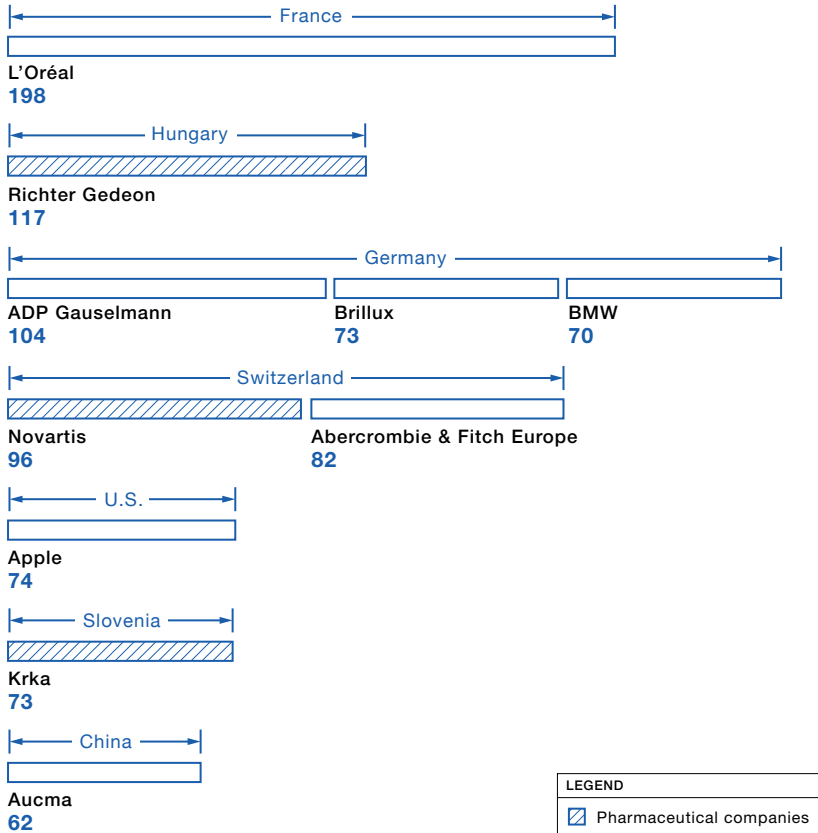

Source: WIPO Statistics Database, September 2018.

Filing 198 applications in 2017, cosmetics and beauty giant L'Oréal of France held its position as the top Madrid applicant for the second year in a row. It was followed by pharmaceutical company Richter Gedeon (117) of Hungary, Germany-based games-maker ADP Gauselmann (104), and pharmaceutical company Novartis (96) and retailer Abercrombie & Fitch Europe (82), both based in Switzerland. Sixth-ranked Apple (74) of the U.S. moved up seven places from 13th in 2016.

Industrial designs

More than half of all designs in applications filed worldwide were received by the IP office of China

20. Percentage shares of total design filing activity by the top five offices

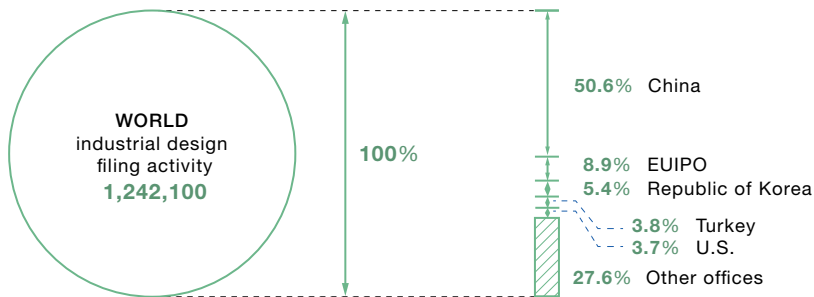

EUIPO is the European Union Intellectual Property Office.

Source: WIPO Statistics Database, September 2018.

WIPO uses the application design count to measure filing activity for industrial designs; in other words, it does not just count the number of applications, but counts the number of designs in applications. Design count is a better way of comparing filing activity across IP offices, because at some offices users can register multiple designs through a single application.

In 2017, about 945,100 industrial design applications were filed worldwide. These applications contained a total of 1.24 million designs.

Almost 85% of global industrial design filing activity – as measured in design counts – took place in the top ten offices in 2017, with the office of China alone receiving 50.6% the world total. The EUIPO (8.9%) and the Republic of Korea (5.4%) received the second and third largest shares of total filing activity.

China received far more application design counts than any other office

21. Application design counts for the top 10 offices

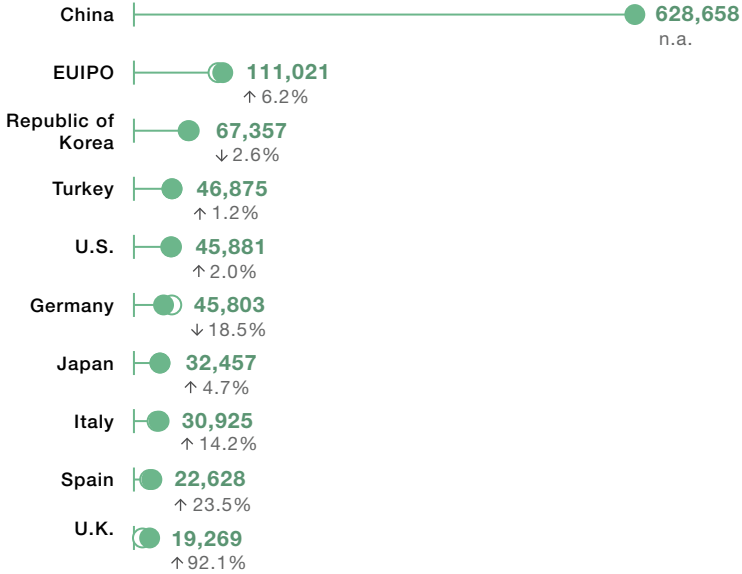

LEGEND	
○	2016
●	2017

n.a. indicates not available. China's 2017 data are not comparable with its previous year's data due to a change in how this office counts the applications it receives. For this reason it is not possible to report China's 2017 growth rate.

EUIPO is the European Union Intellectual Property Office.

Source: WIPO Statistics Database, September 2017.

Italy (+14.2%), Spain (+23.5%) and the U.K. (+92.1%) all recorded strong annual growth in the number of designs in applications received in 2017, whereas Germany (-18.5%) and the Republic of Korea (-2.6%) were the only two among the top 10 offices to have received fewer designs in applications in 2017 than in 2016.

Among offices of middle-income countries, filing activity was particularly high in the Islamic Republic of Iran

22. Application design counts for offices of selected middle-income countries

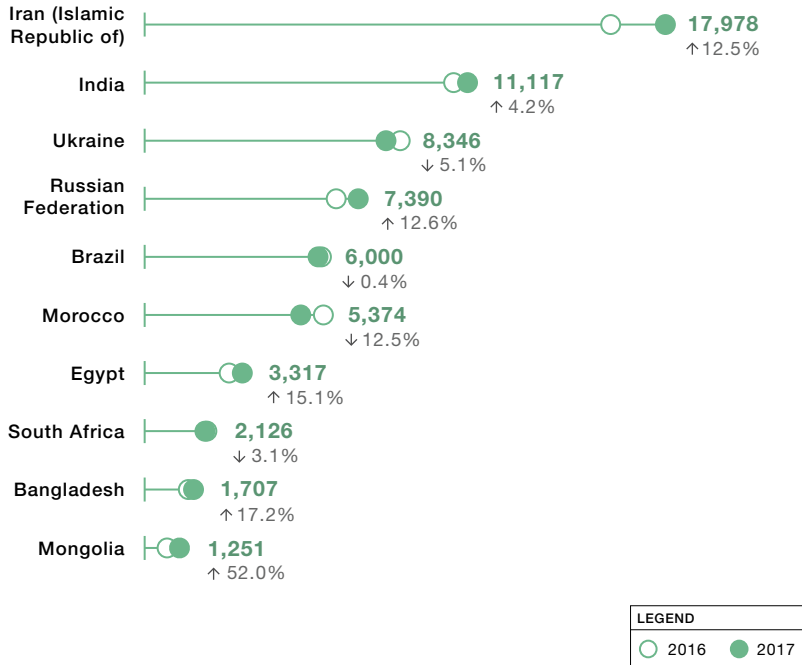

Source: WIPO Statistics Database, September 2018.

With nearly 18,000 designs in applications received, the IP office of the Islamic Republic of Iran had considerably higher filing activity than offices of most other middle-income countries in 2017. India (11,117 designs), Ukraine (8,346), the Russian Federation (7,390), Brazil (6,000) and Morocco (5,374) also ranked among the top 10 offices in terms of design filing activity.

The chart above shows the total numbers of designs contained in applications filed at IP offices of selected middle-income countries in 2017. For application design counts for all other IP offices (where available), see the statistical table starting on page 39.

The Republic of Korea leads the world in the number of designs in applications per unit of GDP (USD 100 billion)

23. Resident application design count relative to GDP for the top 10 origins

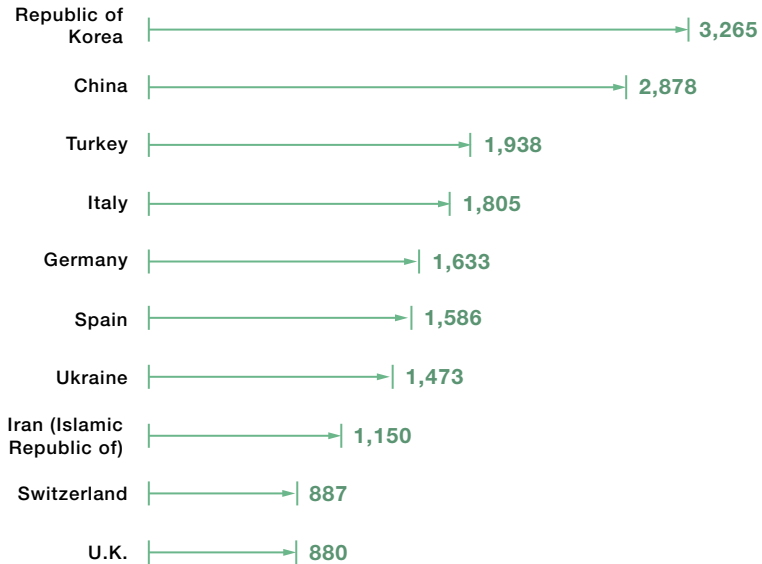

Sources: WIPO Statistics Database and World Bank, September 2018.

Calculating design counts per unit of GDP enables a comparison of industrial design filing activity by residents of countries with different filing systems (single-design versus multi-design) and economies of different sizes. On this measure, the Republic of Korea performed strongly. It had the highest resident design count per unit of GDP in 2017, followed by China, Turkey, Italy and Germany, making the same top five origins as in 2016.

Which industries led design filing by applicants from different countries?

24. The top three industry sectors for each of the selected origins

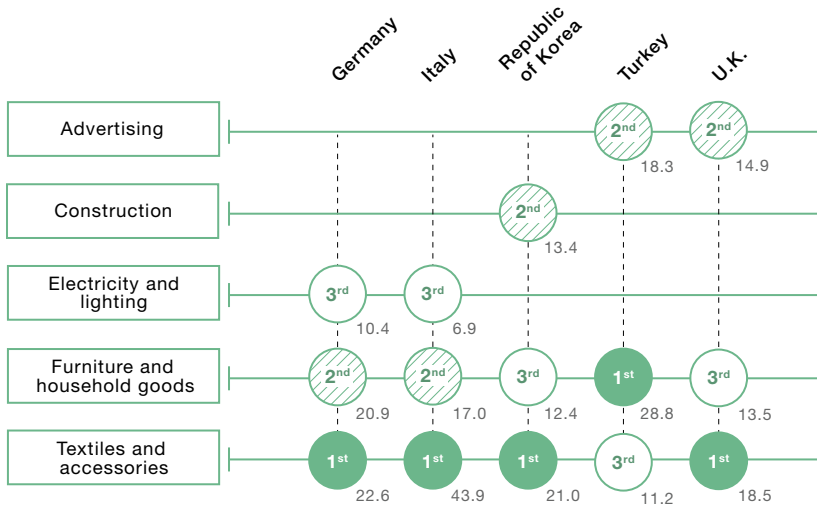

Numbers in gray show percentage share.

Source: WIPO Statistics Database, September 2018.

Grouping the 32 Locarno classes into 12 industry sectors allows us to analyze the areas of strength or specialization of different countries. Both the furniture and household goods sector and the textiles and accessories sector featured among the top three sectors for industrial design filings for all five of the selected origins. Construction was one of the top three sectors for applicants located in the Republic of Korea, whereas advertising ranked among the top three for those in Turkey and the U.K., and electricity and lighting for applicants based in Germany and Italy.

Germany, Switzerland and the Republic of Korea were the three largest users of the Hague System

25. Designs in Hague international applications for the top 10 origins

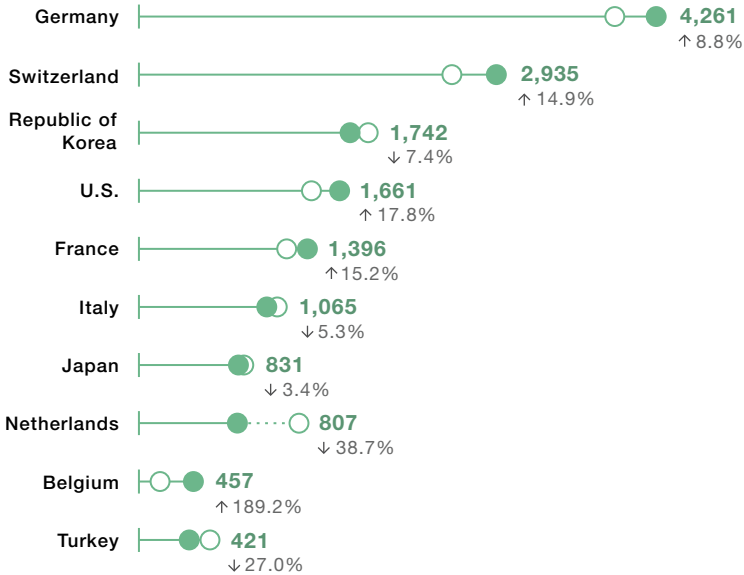

LEGEND	
○	2016
●	2017

Source: WIPO Statistics Database, September 2018.

The Hague System makes it possible for an applicant to obtain protection for industrial designs in multiple jurisdictions by filing a single application with the International Bureau of WIPO. It simplifies the process of multinational registration by eliminating the requirement to file a separate application in each jurisdiction in which protection is sought. Hague applicants can protect up to 100 industrial designs for products belonging to one and the same class through a single application.

In 2017, the Hague System received 5,213 international applications, down 6.3% on 2016. However, these applications contained 19,429 designs representing an annual growth of 3.8%. The number of designs in Hague applications has continuously increased since 2007.

Applicants based in Germany remained the largest users of the Hague System, with 4,261 designs in applications. They were followed by those residing in Switzerland (2,935), the Republic of Korea (1,742), the U.S. (1,661) and France (1,396). These five origins combined accounted for around 62% of the total. While France (+15.2%), Germany (+8.8%), Switzerland (+14.9%) and the U.S. (+17.8%) all experienced sharp increases in design count, the Republic of Korea (-7.4%) saw its first decline in design count since joining the Hague System in 2014.

Two electronics giants from the Republic of Korea lead the top applicants list

26. Top 10 Hague applicants

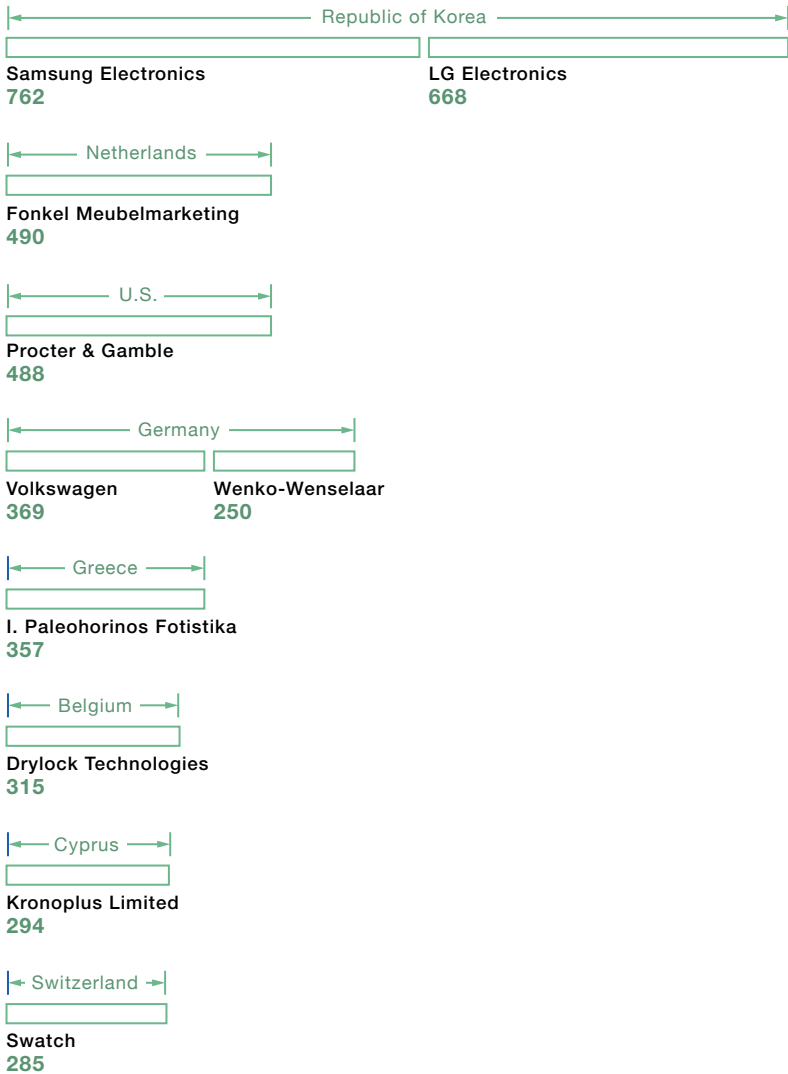

Source: WIPO Statistics Database, September 2018.

Two electronics giants from the Republic of Korea, Samsung Electronics (762 designs) and LG Electronics (668), ranked first and second among the top applicants. The Netherlands' Fonkel Meubelmarketing (490) dropped from first position in 2016 to third in 2017. Procter & Gamble of the U.S. (488) and Volkswagen of Germany (369) were fourth and fifth, respectively.

The top 10 applicants represent a diverse set of industries, including automobiles, decorative lighting, electronics, furnishing, household goods, software and computer services, and watches and jewelry.

Additional information

Statistical tables

Applications by office, 2017

IP office ^a	Applications			
	Patent	Utility model	Trademark class count ^b	Industrial design count ^c
African Intellectual Property Organization	519	..	12,233	933
African Regional Intellectual Property Organization	747	17	782	90
Albania	24	1	8,391	..
Andorra	6	..	3,086	..
Antigua and Barbuda	8
Argentina	3,443	225	74,722	1,649
Armenia	110	40	10,043	638
Australia	28,906	1,816	138,078	7,708
Austria	2,305	595	22,748	..
Bahamas	52	..	1,002	..
Bahrain	245	..	9,418	79
Bangladesh	302	..	13,090	1,707
Barbados	861	1
Belarus	524	453	18,961	583
Belgium ^d	1,217
Benelux Office for Intellectual Property	67,205	1,469
Bhutan	3	..	1,921	..
Bolivia (Plurinational State of)	336	18	8,204	59
Bosnia and Herzegovina	99	..	10,031	1,126
Botswana	7	5	3,134	..
Brazil	25,658	2,918	186,103	6,000
Brunei Darussalam	107	..	2,834	265
Bulgaria	225	281	17,552	897
Burundi	534	..
Canada	35,022	..	183,735	6,533
Chile	2,894	142	45,360	438
China	1,381,594	1,687,593	5,739,823	628,658
China, Hong Kong (SAR)	13,299	693	76,521	4,816
China, Macao (SAR)	68	18	13,135	193
Colombia	2,372	216	41,076	556
Costa Rica	523	14	14,405	52
Croatia	159	53	8,272	1,041
Cuba	174	2	7,308	12
Curaçao	1,996	..
Cyprus	12	58
Czech Republic	860	1,279	25,339	855
Denmark	1,772	132	11,135	554

IP office ^a	Applications			
	Patent	Utility model	Trademark class count ^b	Industrial design count ^c
Dominican Republic	289	9	13,613	35
Ecuador	417	49	14,551	297
Egypt	3,317
El Salvador	182	104	9,082	49
Estonia	41	55	5,493	320
Eurasian Patent Organization	3,302
European Patent Office	166,585
European Union Intellectual Property Office	371,508	111,021
Finland	1,529	509	9,376	495
France	16,247	428	270,412	12,132
Gambia	4	1	1,782	..
Georgia	232	57	10,746	1,193
Germany	67,712	13,301	225,768	45,803
Ghana	26	7	5,041	963
Greece	589	16	..	1,424
Grenada	41	..
Guatemala	278	11	12,012	245
Guyana	23
Honduras	193	10	7,077	24
Hungary	532	235	14,324	917
Iceland	44	..	9,179	597
India	46,582	..	283,575	11,117
Indonesia	9,303	292	68,108	3,641
Iran (Islamic Republic of)	16,259	..	358,353	17,978
Iraq	714
Ireland	269	..	7,648	155
Israel	6,813	..	19,491	1,656
Italy	9,674	2,095	93,006	30,925
Jamaica	68	..	5,595	140
Japan	318,479	6,105	560,269	32,457
Jordan	200	..	7,647	103
Kazakhstan	1,228	833	..	203
Kenya	178	153	12,043	148
Kyrgyzstan	146	22	7,503	490
Latvia	97	..	7,099	355
Liechtenstein ^e	8,877	1,311
Lithuania	127	..	7,858	794
Luxembourg ^d	668
Madagascar	51	..	5,396	186
Malaysia	7,072	206	41,093	1,814
Malta	1,167	..
Mauritius	19	..	2,092	..
Mexico	17,184	619	151,771	4,233
Monaco	35	..	9,208	1,173
Mongolia	228	255	13,845	1,251

IP office ^a	Applications			
	Patent	Utility model	Trademark class count ^b	Industrial design count ^c
Morocco	2,224	..	30,031	5,374
Namibia	25	..	7,135	..
Nepal	63	..	5,682	40
Netherlands ^d	2,606
New Zealand	6,160	..	47,173	1,291
Norway	2,060	..	42,897	4,521
Pakistan	698	..	38,425	490
Panama	409	4	10,582	63
Patent Office of the Cooperation Council for the Arab States of the Gulf	1,846
Peru	1,219	280	33,031	349
Philippines	3,395	1,462	51,502	1,417
Poland	4,041	1,008	40,434	..
Portugal	680	97	33,287	1,663
Qatar	593	..	8,124	..
Republic of Korea	204,775	6,811	230,466	67,357
Republic of Moldova	110	142	11,300	1,011
Romania	1,178	53	22,987	1,147
Russian Federation	36,883	10,643	291,732	7,390
Rwanda	456	9	2,536	..
Saint Kitts and Nevis	9	..	339	..
Saint Vincent and the Grenadines	3	..	365	..
Samoa	246	..
Sao Tome and Principe	1,267	..
Saudi Arabia	3,191	1,001
Serbia	184	75	16,090	1,389
Seychelles	50	..
Singapore	10,930	..	48,548	4,917
Slovakia	206	412	14,080	465
South Africa	7,544	..	26,251	2,126
Spain	2,343	2,465	80,889	22,628
Sri Lanka	543	336
Sudan	293	..	5,004	545
Suriname	1,162	..
Sweden	2,297	..	22,815	615
Switzerland	1,628	..	94,562	13,114
Syrian Arab Republic	136	..	17,461	759
Thailand	7,865	2,517	53,965	5,122
The former Yugoslav Republic of Macedonia	1,025
Trinidad and Tobago	171	..	2,558	300
Tunisia	555	..	13,281	1,381
Turkey	8,555	3,320	247,474	46,875
Uganda	1,474	..
Ukraine	4,047	9,108	72,015	8,346
United Arab Emirates	1,800	17	19,042	..

IP office ^a	Applications			
	Patent	Utility model	Trademark class count ^b	Industrial design count ^c
United Kingdom	22,072	..	176,202	19,269
United States of America	606,956	..	613,921	45,881
Uruguay	523	36	9,311	115
Uzbekistan	553	146	13,242	343
Venezuela (Bolivarian Republic of)	434	..	22,439	..
Viet Nam	5,382	434	84,764	3,183
Yemen	28	..	4,713	27
Zambia	22	..	4,474	30
World total (2017 estimate)	3,168,900	1,761,200	12,387,600	1,242,100

a. Not all listed countries/territories/intergovernmental organizations have an IP office. Also, some offices do not receive applications for some IP rights. Only those offices with at least one application filed are presented.

b. Application class count is the sum of classes specified in applications received directly by an office plus, where applicable, those specified in designations received by the office via the Madrid System.

c. Application design count is the sum of designs contained in applications received directly by an office plus, where applicable, those contained in designations received by the office via the Hague System.

d. This country does not have a national trademark or industrial design office. All applications for trademark and design protection are filed at the Benelux Office for Intellectual Property (BOIP) or the European Union Intellectual Property Office (EUIPO).

e. The Swiss Federal Institute of Intellectual Property acts as the receiving office for patent applications.

.. indicates either zero, not available or not applicable.

Source: WIPO Statistics Database, September 2018.

International applications by origin via the PCT, Madrid and Hague Systems, 2017

Origin ^a	International applications		
	PCT	Madrid	Hague ^b
Albania	7	12	..
Algeria	12	9	..
Andorra	5
Antigua and Barbuda	57
Argentina	36	3	..
Armenia	5	37	3
Australia	1,852	2,122	4
Austria	1,397	1,050	241
Azerbaijan	10	12	..
Bahamas	5	12	..
Bahrain	1
Barbados	67	4	..
Belarus	28	142	..
Belgium	1,354	774	457
Belize	2	37	..
Bermuda	..	8	..
Bonaire, Sint Eustatius and Saba	..	1	..
Bosnia and Herzegovina	5	33	8
Botswana	1
Brazil	589	3	..
Brunei Darussalam	2	2	..
Bulgaria	50	190	41
Cambodia	1
Cameroon	1
Canada	2,399	60	4
Chad	1
Chile	167
China	48,900	6,066	161
China, Hong Kong (SAR)	1
Colombia	143	32	..
Congo	..	1	..
Costa Rica	10
Côte d'Ivoire	2
Croatia	35	110	34
Cuba	8	9	..
Curaçao	..	11	..
Cyprus	51	204	395
Czech Republic	184	298	151
Democratic People's Republic of Korea	2	6	..
Denmark	1,429	598	251
Dominican Republic	13
Ecuador	5
Egypt	36	20	..
El Salvador	1

Origin ^a	International applications		
	PCT	Madrid	Hague ^b
Estonia	47	73	13
Finland	1,601	542	81
France	8,013	4,260	1,396
Georgia	10	30	..
Germany	18,948	7,319	4,261
Greece	110	141	371
Guatemala	1	1	..
Guinea	1
Hungary	147	239	30
Iceland	39	43	1
India	1,583	233	4
Indonesia	8	1	1
Iran (Islamic Republic of)	88	37	..
Iraq	2
Ireland	486	164	20
Israel	1,817	323	1
Italy	3,225	2,877	1,065
Jamaica	1
Japan	48,206	2,542	831
Jordan	6	1	..
Kazakhstan	27	111	..
Kenya	8	2	..
Kuwait	4
Kyrgyzstan	..	5	1
Lao People's Democratic Republic	..	2	..
Latvia	26	109	1
Lebanon	5	1	..
Liberia	1	1	..
Libya	3
Liechtenstein	263	87	87
Lithuania	30	120	13
Luxembourg	498	386	97
Madagascar	..	2	..
Malaysia	141	13	..
Malta	97	72	2
Mauritius	3	13	..
Mexico	270	107	..
Monaco	15	52	4
Mongolia	..	1	..
Montenegro	1	15	1
Morocco	47	110	3
Mozambique	..	4	..
Namibia	2
Netherlands	4,430	1,417	807
New Zealand	273	419	..

Origin ^a	International applications		
	PCT	Madrid	Hague ^b
Nigeria	6
Norway	820	376	169
Oman	3
Pakistan	3
Panama	9	3	..
Peru	33
Philippines	18	54	..
Poland	330	416	142
Portugal	201	265	80
Qatar	26	1	5
Republic of Korea	15,752	1,034	1,742
Republic of Moldova	8	49	2
Romania	31	106	45
Russian Federation	1,061	1,460	..
Saint Kitts and Nevis	1	3	..
Samoa	1
San Marino	5	10	..
Saudi Arabia	378	3	..
Senegal	4
Serbia	19	178	57
Seychelles	4	10	..
Singapore	867	517	13
Sint Maarten (Dutch Part)	..	1	..
Slovakia	52	123	59
Slovenia	99	208	120
South Africa	295	3	..
Spain	1,418	1,317	219
Sri Lanka	19	2	..
Sudan	11
Suriname	..	1	..
Sweden	3,975	863	276
Switzerland	4,485	3,269	2,935
Syrian Arab Republic	1
Thailand	156	25	..
The former Yugoslav Republic of Macedonia	2	39	..
Togo	1
Trinidad and Tobago	3
Tunisia	9	24	..
Turkey	1,203	1,304	421
Turkmenistan	..	7	..
Ukraine	141	388	179
United Arab Emirates	95	20	2
United Kingdom	5,569	3,297	355
United Republic of Tanzania	..	1	..

WIPO IP FACTS AND FIGURES

Origin ^a	International applications		
	PCT	Madrid	Hague ^b
United States of America	56,680	7,889	1,661
Uruguay	14
Uzbekistan	4	16	..
Vanuatu	1
Venezuela (Bolivarian Republic of)	2
Viet Nam	23	91	..
Zimbabwe	21
Others/Unknown	249	25	105
Total	243,464	57,139	19,429

a. Origin is defined as the country/territory of the stated address of residence of the applicant. Where more than one applicant is listed in an application, the origin is based on the first named applicant. Only origins with at least one international application filed in 2017 are presented.

b. Data represent the number of designs contained in Hague international applications.

.. indicates zero or not applicable.

Source: WIPO Statistics Database, September 2018.

Statistical resources

IP Statistics Data Center

The WIPO IP Statistics Data Center is a free online service for accessing WIPO's statistics on patents, utility models, trademarks, industrial designs and the use of the PCT, Madrid and Hague Systems. Users can select from a wide range of indicators to view or download data. This tool is intended for IP professionals, researchers and policymakers and can be accessed via the IP Statistics webpage: www.wipo.int/ipstats.

IP Statistical Country Profiles

Visit WIPO's IP Statistical Country Profile webpages for more statistics and longer time series for patent, utility model, trademark and industrial design data. Like WIPO's IP Statistics Data Center, this service can be accessed via the IP Statistics webpage: www.wipo.int/ipstats.

The IP Statistical Country Profiles are also available in French and Spanish.

Glossary

Class count

The number of classes specified in a trademark application or registration. In the international trademark system and at certain national and regional offices, an applicant can file a trademark application that specifies one or more of the 45 goods and services classes of the Nice Classification. Offices use a single- or multi-class filing system. For example, the offices of Japan, the Republic of Korea and the United States of America (U.S.), as well as many European IP offices, have multi-class filing systems. The offices of Brazil, Mexico and South Africa follow a single-class filing system, requiring a separate application for each class in which an applicant seeks trademark protection. To capture the differences in application and registration numbers across offices, it is useful to compare their respective application and registration class counts.

Design count

The number of designs contained in an industrial design application or registration. Under the Hague System for the International Registration of Industrial Designs, it is possible for an applicant to obtain protection for up to 100 industrial designs for products belonging to one and the same class by filing a single application. Some national or regional IP offices allow applications to contain more than one design for the same product or within the same class, while others allow only one design per application. In order to capture the differences in application and registration numbers across offices, it is useful to compare their respective application and registration design counts.

Hague international application

An application for the international registration of an industrial design filed under the WIPO-administered Hague System.

Hague System

The abbreviated form of the Hague System for the International Registration of Industrial Designs. This System comprises two international treaties: the Hague Act of 1960 and the Geneva Act of 1999. The Hague System makes it possible for an applicant to register up to 100 industrial designs in multiple jurisdictions by filing a single application with the International Bureau of WIPO. It simplifies multinational registration by reducing the requirement to file separate applications with each IP office. The System also simplifies the subsequent management of the industrial design, since it is possible to record changes or renew a registration through a single procedural step.

Industrial design

Industrial designs are applied to a wide variety of industrial products and hand-crafts. They refer to the ornamental or aesthetic aspects of a useful article, including compositions of lines or colors or any three-dimensional forms that give a special appearance to a product or handicraft. The holder of a registered industrial design has exclusive rights against unauthorized copying or imitation of the design by third parties. Industrial design registrations are valid for a limited period. The term of protection is 15 years in most jurisdictions. However, differences in legislation exist, notably in China (which provides for a 10-year term from the application date).

In force

Refers to IP rights that are currently valid or, in the case of trademarks, active. To remain in force, IP protection must be maintained.

Intellectual property (IP)

Refers to creations of the mind: inventions, literary and artistic works, and symbols, names, images and designs used in commerce. IP is divided into two categories: industrial property – which includes patents, utility models, trademarks, industrial designs and geographical indications of source – and copyright, which includes literary and artistic works such as (novels, poems, plays, films), musical works, artistic works (such as drawings, paintings, photographs and sculptures) and architectural designs. Rights related to copyright include those of performing artists in their performances, those of producers of sound recordings in their recordings and those of broadcasters in their radio and television programs.

Madrid international application

An application for international registration under the Madrid System, which is a request for protection of a trademark in one or more Madrid members' jurisdictions. An international application must be based on a basic mark – prior application or registration of a mark in a Madrid member.

Madrid System

An abbreviation describing two procedural treaties for the international registration of trademarks; namely, the Madrid Agreement for the International Registration of Marks and the Protocol relating to that Agreement. The Madrid System is administered by the International Bureau of WIPO.

Patent

A set of exclusive rights granted by law to applicants for inventions that are new, non-obvious and commercially applicable. A patent is valid for a limited period (generally 20 years), during which time patent holders can commercially exploit their inventions on an exclusive basis. In return, applicants are obliged to disclose their inventions to the public in a manner that enables others skilled in the art to replicate the invention. The patent system is designed to encourage innovation by providing innovators with time-limited exclusive legal rights, thus enabling them to appropriate the returns from their innovative activity.

PCT application

A patent application filed through the WIPO-administered PCT, also known as an international application.

PCT System

The PCT, an international treaty administered by WIPO, facilitates the acquisition of patent rights in a large number of jurisdictions. The PCT System simplifies the process of multiple national patent filings by reducing the requirement to file a separate application in each jurisdiction. However, the decision on whether to grant patent rights remains in the hands of national and regional patent offices, and patent rights remain limited to the jurisdiction of the patent-granting authority. The PCT application process starts with the international phase, during which an international search and, possibly, a preliminary examination are performed, and concludes with the national phase, during which a national or regional patent office decides on the patentability of an invention according to national law.

Resident

For statistical purposes, a resident application refers to an application filed with the IP office of, or acting for, the state or jurisdiction in which the first named applicant in the application has residence. For example, an application filed with the Japan Patent Office (JPO) by a resident of Japan is considered a resident application from the perspective of the JPO. Resident applications are sometimes referred to as “domestic applications.” A resident grant/registration is an IP right issued on the basis of a resident application.

Trademark

A sign used to distinguish the goods or services of one undertaking from those of others. A trademark may consist of words and combinations of words (for instance, names or slogans), logos, figures and images, letters, numbers, sounds, or, in rare instances, smells or moving images, or a combination thereof.

The procedures for registering trademarks are governed by the legislation and procedures of national and regional IP offices and WIPO. Trademark rights are limited to the jurisdiction of the IP office that registers the trademark. Trademarks can be registered by filing an application at the relevant national or regional office(s), or by filing an international application through the Madrid System.

Utility model

A special form of patent right granted by a state or jurisdiction to an inventor or the inventor's assignee for a fixed period of time. The terms and conditions for granting a utility model are slightly different from those for normal patents (including a shorter term of protection and less stringent patentability requirements). The term can also describe what are known in certain countries as "petty patents," "short-term patents" or "innovation patents."

World Intellectual Property Organization (WIPO)

A United Nations specialized agency dedicated to the promotion of innovation and creativity for the economic, social and cultural development of all countries through a balanced and effective international IP system. WIPO was established in 1967 with a mandate to promote the protection of IP throughout the world through cooperation between states and in collaboration with other international organizations.

World Intellectual Property Organization
34, chemin des Colombettes
P.O. Box 18
CH-1211 Geneva 20
Switzerland

Tel: +41 22 338 91 11
Fax: +41 22 733 54 28

For contact details of WIPO's
External Offices visit:
www.wipo.int/about-wipo/en/offices/

WIPO Publication No. 943E/18
ISBN 978-92-805-2914-2